



The XLA Series is a TRIAC/ELV dimmable LED driver series, which offers maximum dimming performance and the widest dimming compatibility, in the market today. Incorporating proprietary smart-dim technology, the XLA series provides flicker-free, 0-100% dimming and has been tested to work with over 60 brand name dimmers on the market. Rated for up to 18 Watts of output power, the XLA 18 comes in 4 unique designs, suitable for a wide variety of LED illumination applications.

XLA18

Forward/Reverse Phase Dimmable LED Driver



Model Selection Key

XLA(A) 18-BCV-D

- LT: long thin outdoor version
- SWI: short wide, 2 AC/2 DC wires, indoor version
- SWO: short wide, 2 AC/2 DC wires, outdoor version
- SWC: short wide, 3 AC/2 DC input/output push on connectors, indoor version
- B: 1 channel output ; C: Max Vout; V: Voltage
- Max Output Power
- H 220-240VAC Input
- L 100-120VAC Input
- Series Name

Features

- Slim Form Factor
- Meets all agency requirements –Class 2UL/cUL/ UL/cUL 1012/ UL 879/ UL 8750/ CE/ FCC Class B
- Built in Over Current, Over Voltage, Over Temperature, and Short Circuit Protection
- IP 66/IP50/IP40 options
- Synchronized Control for Multiple LED lighting fixtures
- TRIAC /ELV dimming
- Wide Operating Temperatures -25C to +60C
- 80,000 hrs MTBF
- 3 year Warranty
- Energy Star Compliant
- Tested to comply with over 60 Industry standard dimmers

Benefits

- Allows flexibility in low-profile fixture design
- Ensures safe operation as well as compliance to LED lighting regulatory requirements for end products
- Ensures smooth operation of the LED Driver without damage to LED circuits
- Suitable for both indoor/outdoor environments
- Ensures uniform dimming performance across multiple LED lighting fixtures
- 0-100% smooth flicker-free dimming
- Dependable operation in extreme environments
- Complements LED life expectancy
- Provides better value and peace of mind to customers
- Enables complete lighting system energy star compliance and enhances system value
- Enables lighting fixture/system design flexibility

Applications

- Architectural Lighting
- Effect
- Office General Illumination
- Residential Lighting
- Entertainment Lighting
- Strip Lighting

Part Number		Quick Description	OUTPUT		
100-120VAC Models	200-240 VAC Models		Power (W)	Current (A)	Voltage (V)
XLA(L)18-1100V	XLA(H)18-1100V	18W 0.18A TRIAC/ELV Dim	18	0.18	70 - 105
XLA(L)18-160V	XLA(H)18-160V	18W 0.3A TRIAC/ELV Dim	18	0.3	42 - 63
XLA(L)18-148V	XLA(H)18-148V	16.8W 0.35A TRIAC/ELV Dim	16.8	0.35	33.6 - 50.4
XLA(L)18-142V	XLA(H)18-142V	16.8W 0.4A TRIAC/ELV Dim	16.8	0.4	29.4 - 44.1
XLA(L)18-136V	XLA(H)18-136V	18W 0.5A TRIAC/ELV Dim	18	0.5	25.2 - 37.8
XLA(L)18-130V	XLA(H)18-130V	18W 0.6A TRIAC/ELV Dim	18	0.6	21 - 31.5
XLA(L)18-124V	XLA(H)18-124V	16.8W 0.7A TRIAC/ELV Dim	16.8	0.7	16.8 - 25.2
XLA(L)18-116V	XLA(H)18-116V	16.8W 1.05A TRIAC/ELV Dim	16.8	1.05	11.2 - 16.8
XLA(L)18-112V	XLA(H)18-112V	18W 1.5A TRIAC/ELV Dim	18	1.5	8.4 - 12.6

Input Specification

Voltage Range	Frequency Range	Vmax Inrush Current	Power Factor	TRIAC/ AC Line Dimming Range
XLA(L) Low Input: 100-120VAC XLA(H) High Input: 200-240VAC	47-63 Hz	XLA(L): 30A @ 120VAC Input, 25 °C , cold start-up XLA(H): 60A @ 230VAC Input, 25 °C , cold start-up	0.9 min	0%~100%

Output Specification

Max Power	18 W	Auto-compliance Output Voltage Range	+5%/- 30% Max
Line Regulation	+/- 5% Max	Noise/Ripple	5% of Rated Output Volts (Note: All noise measurements made at the output terminals, connected to a 20Mhz low pass filter)
Current Regulation	+/- 5% Max	Short Circuit Protection	Hiccup-Mode, Auto-Recovery upon removal of short circuit condition
Efficiency	80% Typ. @ full load, 230 VAC Input	Over Voltage Protection	135% Max
Start-up Time	0.5 sec. Typical	Over-current Protection (OCP)	Constant-current limiting
Hold-up Time	0.05mS @ full load, 100 VAC Input	Over temperature Protection	Shutdown- auto recovery

* All noise measurements made at the output terminals, connected to a 20MHz low pass filter.

Environmental Specifications

MTBF	Cooling	Operating Temp	Storage Temp	Relative Humidity	Weatherability
80,000 hours (Full Load @ 25C ambient, Based on MIL-217F)	Convection	-25°C- 60°C (Full load)	-20°C- 85°C	5% - 95 %	IP 66: -SWO, -LT /IP 50: -SWI/ IP 40: -SWC

Compliance / Safety

EMI/RFI	ISPR-22 Class B FCC part 15 Class B EN55015
Safety Agency	UL/CUL 1012/1310 UL8750 UL879 CSA C22.2 No. 107.1 CE (IEC/EN61347-1, IEC/EN61347-2-13) UL #: E342485
Weatherability	EN60529 IP 66/ IP 50/ IP 40 versions available

Remote Dimming Options

Dimming Types	Dimming Control
ELV/TRIAC/SCR	0%~100%

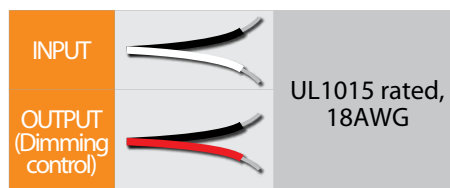

Mechanical

Case Design/ Materials

All versions come in a fully Isolated Class 2 Plastic housing. – LT and –SWO versions are fully potted for IP 66 applications.

Reliabilities Curves

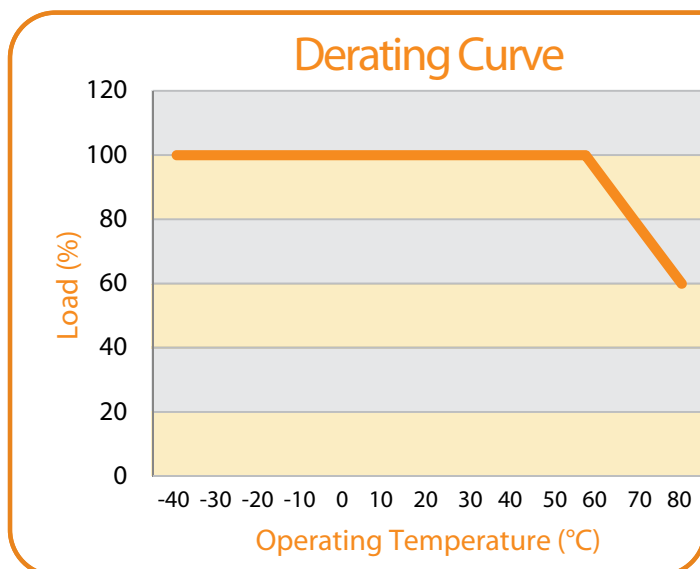
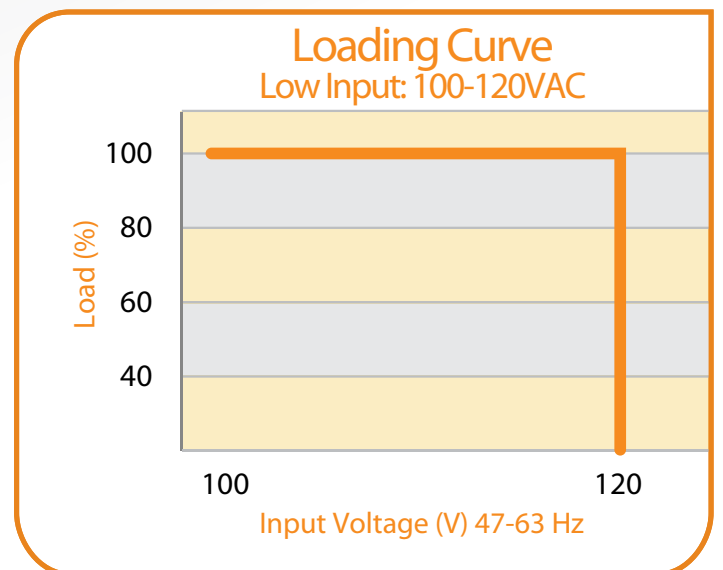
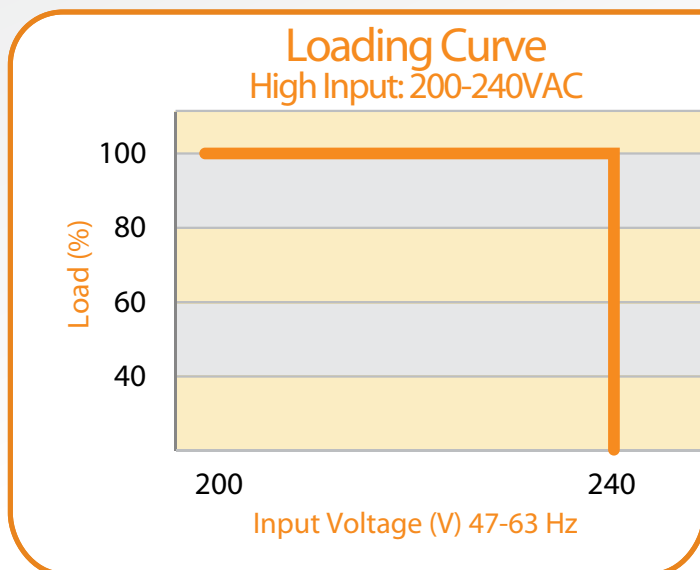
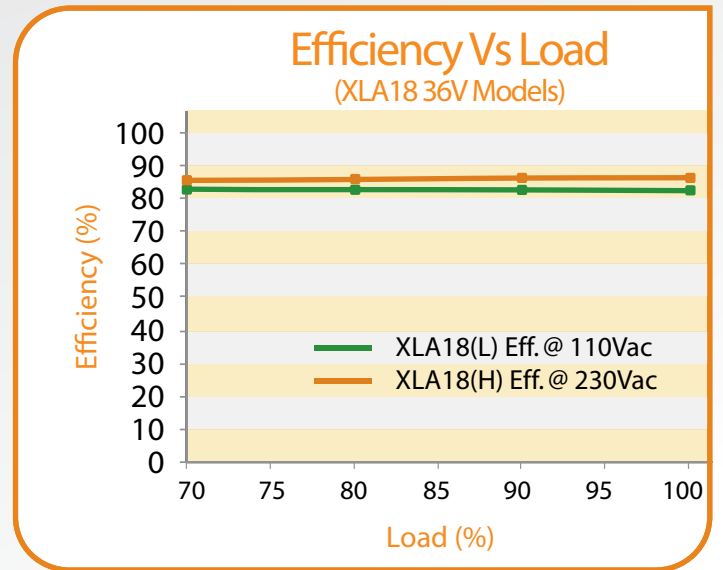
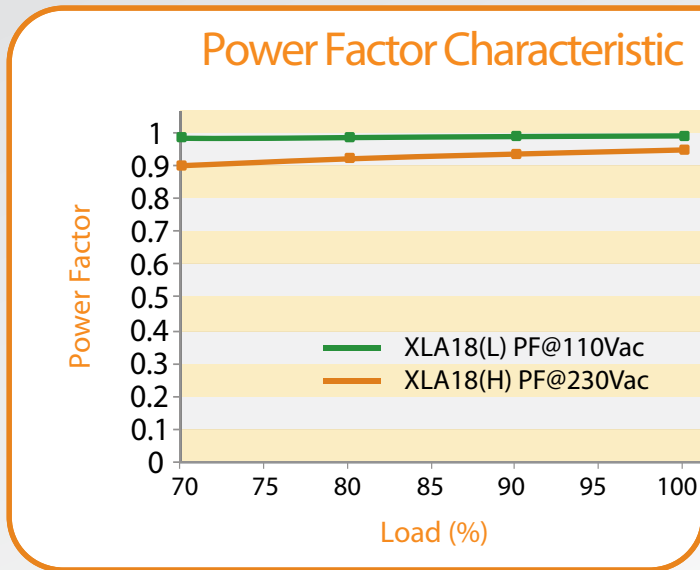

Supported Dimmer List

90~120V AC ELV (Trailing Edge) & Triac (Leading Edge) Dimmer

Brand	Model	Dimmer Rating Power (max)	LED Flicker Free Test *
Cooper Wiring Devices	RI061-A (Rotary Dimmer w/ Non-Preset)	600W	Pass
Cooper Wiring Devices	6001	600W	Pass
Cooper Wiring Devices	SLC03P (C/L)	600W	Pass
Cooper Wiring Devices	SI06P (non C/L)	600W	Pass
GE	DI61-271	600W	Pass
GE	DIB61-71	600W	Pass
GE	DIT61-71	600W	Pass
GE	DIT61-S71	600W	Pass
Gira	1184	400W	Pass
Legrand	RS-100BA-W-CS (Wattstopper occupancy sensor)	500W	Pass
Leviton	6602-IW	600W	Pass
Leviton	L02-700-W	600W	Pass
Leviton	L12-6641-W	600W	Pass
Leviton	No.6641 (Toggle Dimmer)	600W	Pass
Leviton	No.6683-IW (3-Way Push On/Off Dimmer)	600W	Pass
Leviton	R12-6631-LW	600W	Pass
Lutron	DVCL-153PL (C/L)	600W	Pass
Lutron	TGCL-153P (C/L)	600W	Pass
Lutron	AB-600M-WH (Abella)	600W	Pass (##)
Lutron	D-600RH-DK (Rotary)	600W	Pass
Lutron	D-600R-WH (Rotary)	600W	Pass
Lutron	D-603PG-WH (Rotary)	600W	Pass
Lutron	GL-603PH-DK (GLYDER - 3-way)	600W	Pass
Lutron	GL-600-WH (Glyder)	600W	Pass (##)
Lutron	MA-600GH-WH (Ecodim Digital with indicator leds)	500W	Pass (##)
Lutron	MIR-600THW-WH (RC Digital Fade Dimmer)	600W	Pass
Lutron	MS-VP600GHW-WH (Vacancy Sensor w/ eco-dim Dimmer)	600W	Pass(##)
Lutron	S-600PH-WH (SKYLARK)	600W	Pass
Lutron	SELV-300PH-WH (SKYLARK - Single Pole)	300W	Pass
Lutron	TG-600PH-WH (Toggler)	600W	Pass
Lutron	TG-603PFH-WH (Toggler - eco-dim)	600W	Pass
Lutron	TT300NLH-BL	600W	Pass
Lutron	TT-300NLH-BL	300W	Pass
Lutron	D-600PH-DK (non C/L)		

Remarks :

- * - Flicker tests were carried out to ensure full range, flicker-free dimming from min to full load. The XLA series offers the industry's only full-range 0-100% dimming. This is a representative list of dimmers only. GRE Alpha makes no specific recommendation on product selection and there are no warranties of performance or compatibility implied. Refer to dimmer manufacturers for further information on LED compatibility.
- Lutron, Leviton, Legrand, Cooper and their product brand names are registered trademarks of each respective company.

- 5-100% dimming range.

Supported Dimmer List

200~250V AC ELV (Trailing Edge) & Triac (Leading Edge) Dimmer

Brand	Model	Dimmer Rating Power (max)	LED Flicker Free Test *
Air-Lux (Key-Top)	AL-18	600W	Pass
BG-British	BG General	400W	Pass
Brennenstuhl	RD300	300W	Pass
Busch	6513U-102	420W	Pass
Bush-Jaeger	2247U	500W	Pass
Bush-Jaeger	2250U	600W	Pass
Bush-Jaeger	6519U	550W	Pass
Clipsal	32E450UDM	450W	Pass
Clipsal	E32V500/2K	500W	Pass
Clipsal	KB31RD400	400W	Pass
Ehmann	4660	315W	Pass
Ehmann	10UP-kpl	300W	Pass
Ehmann	39 Domus	500W	Pass
Everflourish	EFO700D	300W	Pass
Gira	1184	400W	Pass
HPM	CAT700T	700W	Pass
Italy	DG04027	400W	Pass
JingNeng	JN2301	300W	Pass
KEY-TOP	DP-81	600W	Pass
Legrand	V8051	600W	Pass
LK	DG07103	400W	Pass
Meierte	PDDT	630W	Pass
MK	S1535	1000W	Pass
MK	SX8501	500W	Pass
Opus	852.39	400W	Pass
Opus	852.392	500W	Pass
ShitoneSB	DIM	300W	Pass
Super Star	BP-200	200W	Pass
T&J	P2037S	630W	Pass

Remark:

- * - Flicker tests were carried out to ensure full range, flicker-free dimming from min to full load. The XLA series offers the industry's only full-range 0-100% dimming. This is a representative list of dimmers only. GRE Alpha makes no specific recommendation on product selection and there are no warranties of performance or compatibility implied. Refer to dimmer manufacturers for further information on LED compatibility.
- The above dimmer brand names are registered trademarks of each respective company.

Model Description and Mechanical Diagrams

Outdoor Models: XLA18 – LT

With a long and slender form factor makes this model ideal for width constrained applications.

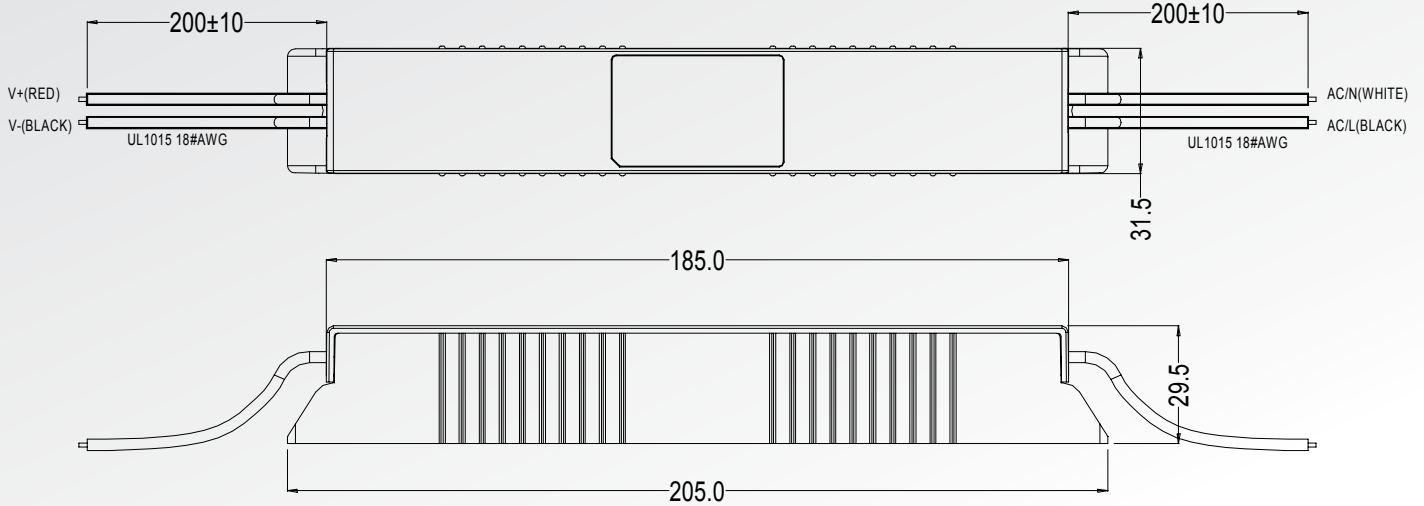

Packing Information

Weight: 0.250 kg/pcs, 16.5 kg/carton
 60 pcs/carton; L457xW407WxH150 (mm)

XLA – SWO & SWI

This compact model fits inside a 4"x4" Junction box making it ideal for space constrained applications.

SWO Models are fully potted for outdoor/damp applications whereas SWI comes un-potted for dry applications.

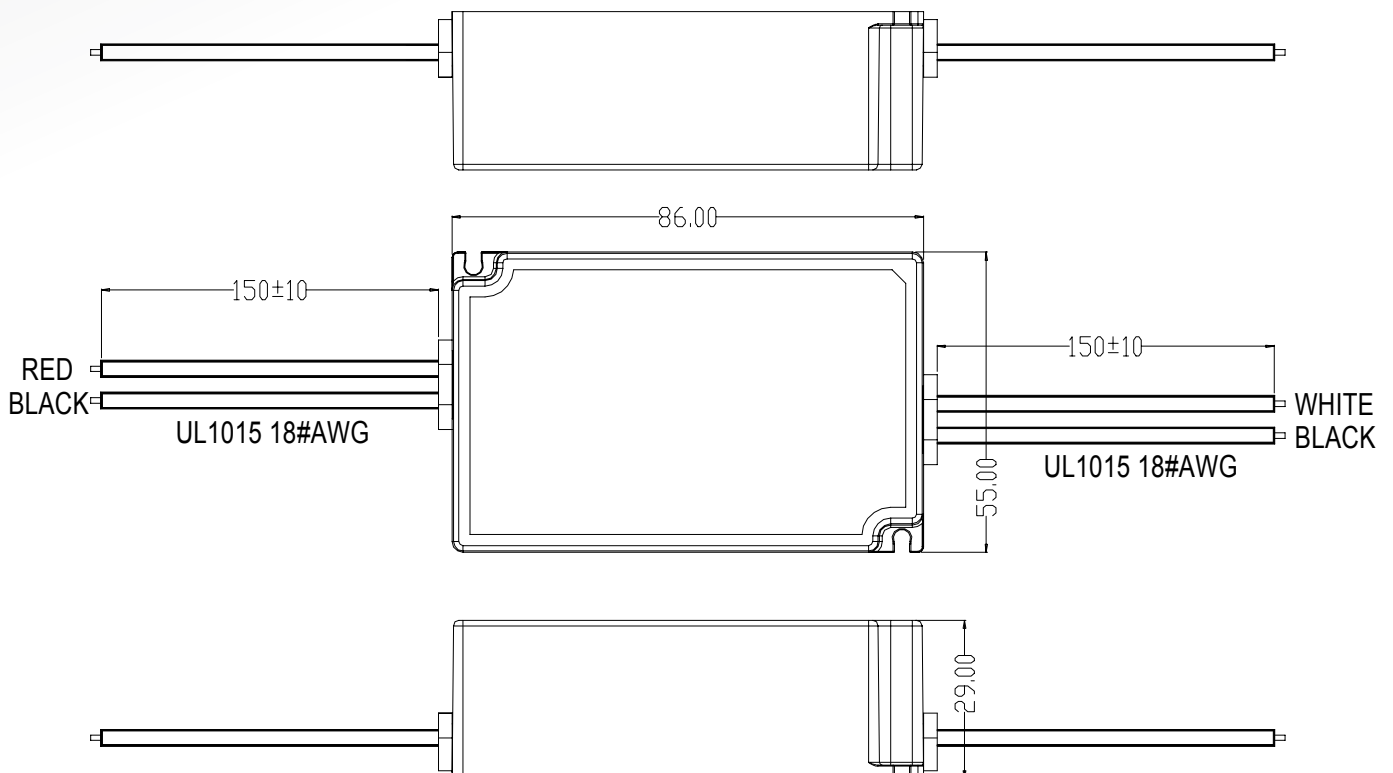

Packing Information for SWO

Weight: 0.263 kg/pcs, 15.0 kg/carton
 50 pcs/carton; L381xW279WxH227 (mm)

Packing Information for SWI

Weight: 0.147 kg/pcs, 9.0 kg/carton
 50 pcs/carton; L381xW279WxH227 (mm)

XLA – SWC

Equipped with plug-and-play connectors, this model accommodates 14-20 AWG wires and provides optimal dimming performance for indoor LED illumination applications.

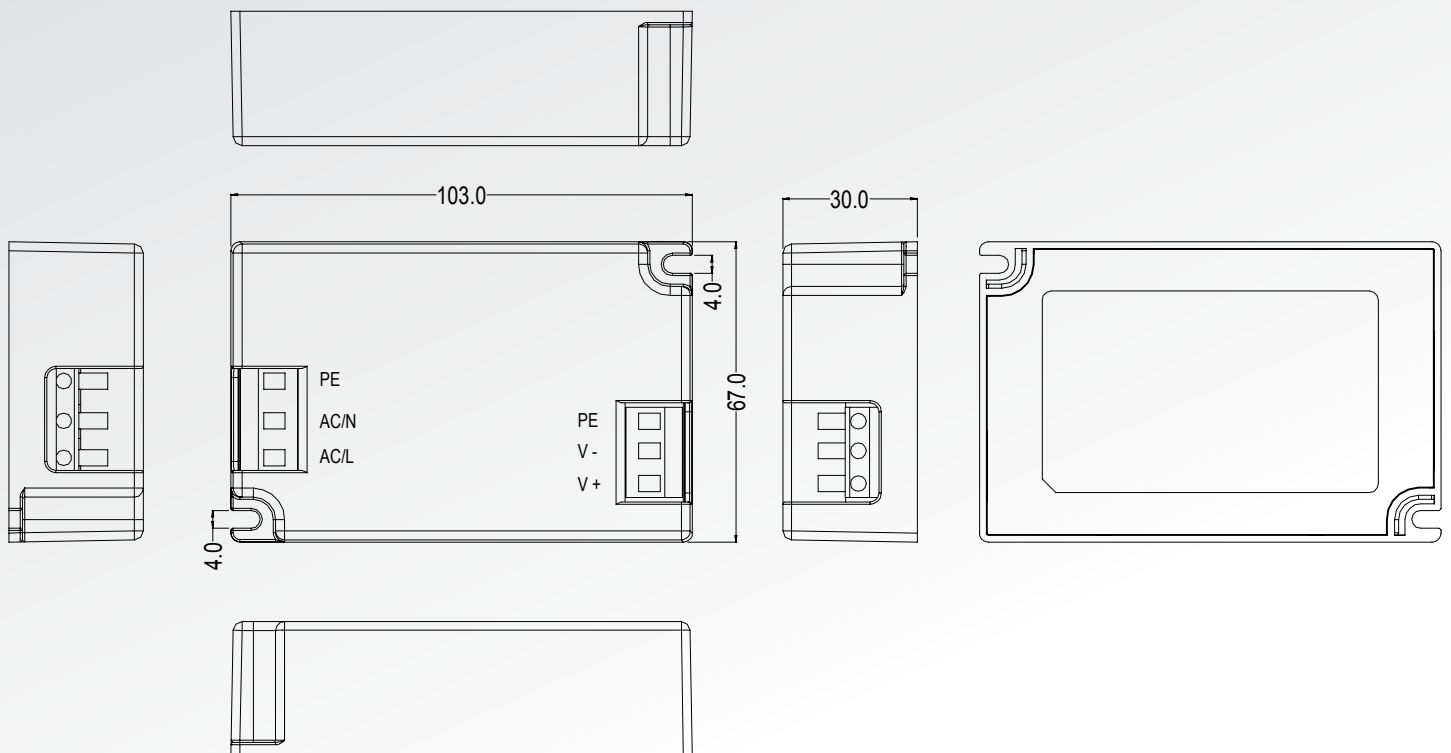

I/O Connector Type:
Terminal Type: Push-On
Voltage Rating VAC: 300V
Wire Area Size Max: 1.5mm²
Wire Size Range (AWG):20-14

Packing Information
Weight: 0.130 kgs/pcs, 14.5 kgs/carton
50 pcs/carton, L480xW412WxH225 (mm)

Wiring Diagrams

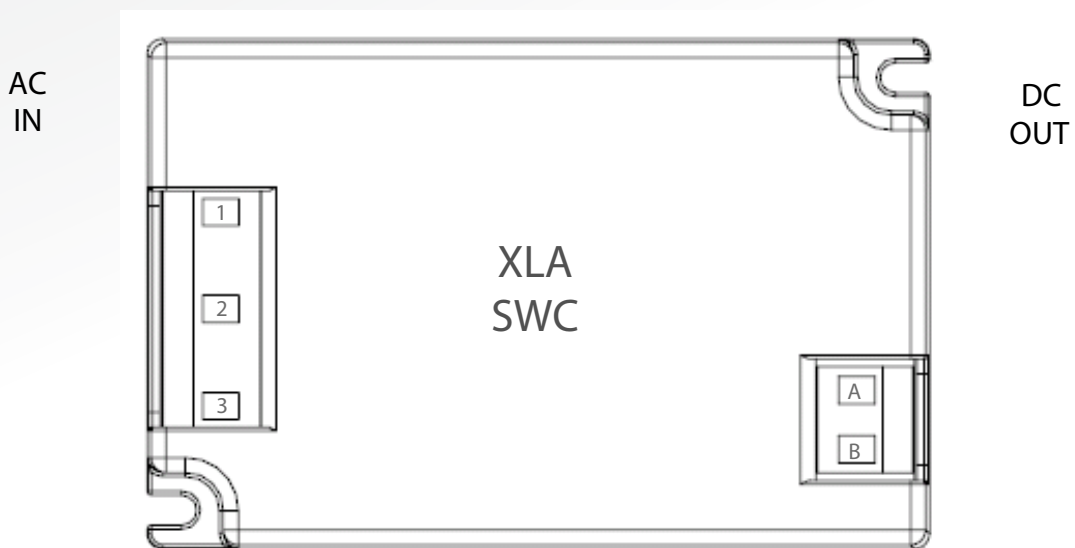
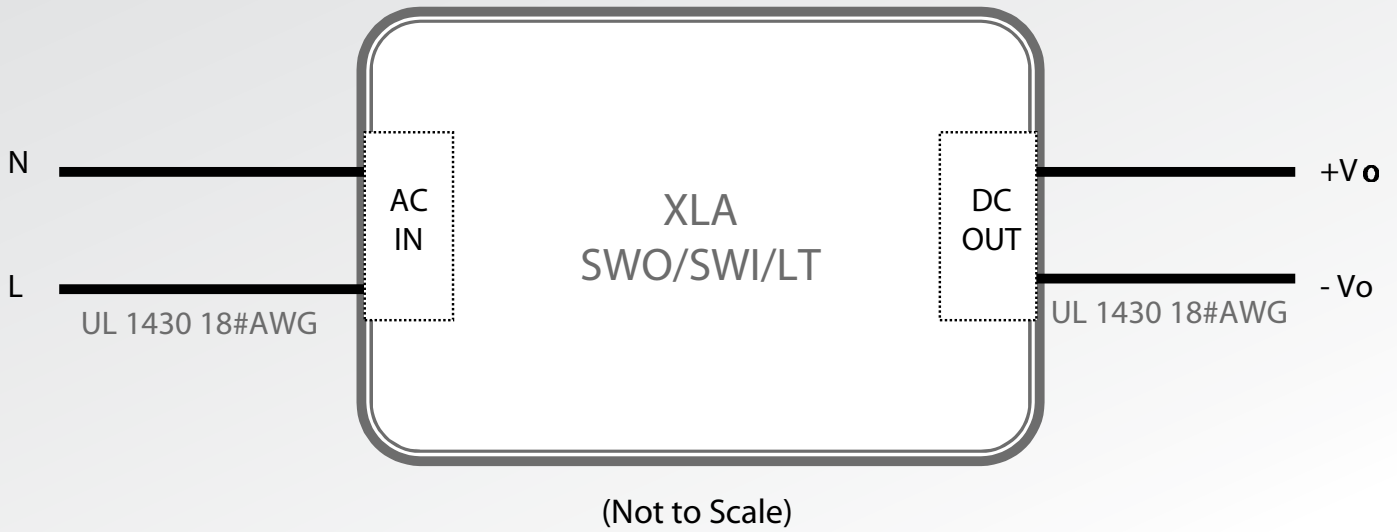

Pin No.	Assignment
1	L
2	N
3	FG
A	-Vo
B	+Vo

Information furnished is believed to be accurate and reliable. However, GRE Alpha assumes no responsibility for the consequences of use of such information nor for any infringement of patents or other rights of third parties which may result from its use. No license is granted by implication or otherwise under any patent or patent rights of GRE Alpha. Specifications mentioned in this publication are subject to change without notice. This publication supersedes and replaces all information previously supplied.

The GRE Alpha logo is a registered trademark of GRE Alpha Electronics Ltd.
 All other names are the property of their respective owners